

INSTRUMENT FEATURES

- SELECTABLE BACKLIGHT COLOUR AND BRIGHTNESS
- HIGH RESOLUTION MODE, 0.1 PSI, 0.1 DEGREE ETC.
- PROGRAMMABLE BUTTON OPTION, RECALL+MENU ETC
- MAXIMUM VALUES STORED AND RECALLED FROM MEMORY.
- INDEPENDENT EXTERNAL & INTERNAL WARNING ALARMS
- EXTERNAL WARNINGS FOR LARGE LED'S OR CONTROL RELAYS
- PROGRAMMABLE LOW BATTERY WARNING
- SELECTABLE AVERAGING FOR PRESSURE.
- SELECTABLE UNITS FOR PRESSURE AND TEMPERATURE
- SOLID STAINLESS PRESSURE SENSORS MEASURE PRESSURE AND VACUUM.
- SPLASH PROOF SENSOR CONNECTORS
- EXTENDED TEMPERATURE RANGE FOR HOT AND COLD CONDITIONS
- THERMOCOUPLE OPTIONS AVAILABLE

INSTALLATION NOTES

Please follow the installation and fitting instructions carefully, and refer to the diagrams on the following pages. Please ensure that the gauge mounted is at least slightly below the driver's eye level to ensure a clear LCD display *.

* Note if the gauge has to be mounted above eye level, then it must be angled down slightly.

[viewing angle.bmp]

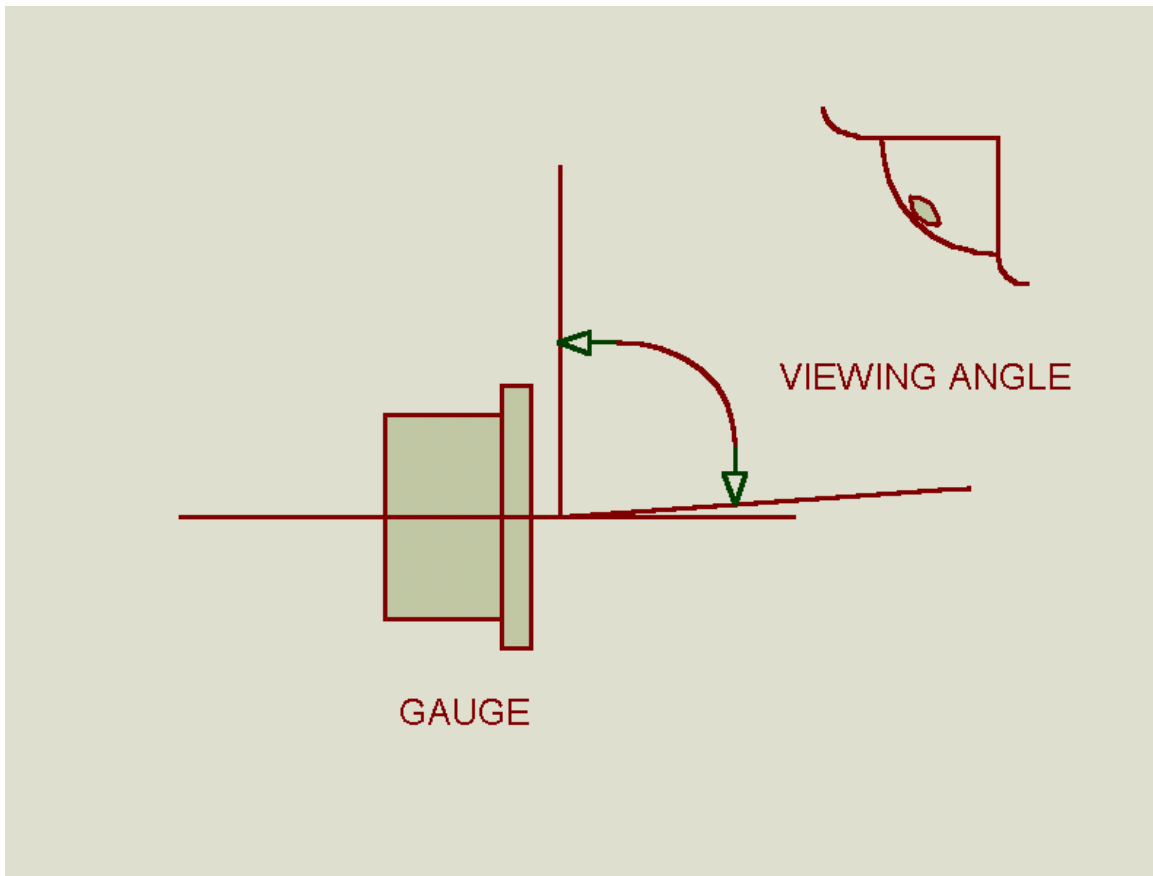

The pressure sensor must be screwed in to a suitable flat surface so that the dowty sealing washer can seal down on to it (see turbo boost pressure installation notes). Please do not over tighten the sensor, the dowty seal does not need to be tight to seal properly.

The temperature sensor has a tapered thread and must be sealed with PTFE tape.

When fitting the pressure sensor plugs, be careful to align the painted marks as shown in the diagram to get correct orientation. The temperature sensor plug has alignment lines moulded into the plug and socket bodies.

If you are fitting the pressure sensor to the output of a pump, and the pressure is pulsing, you may need to increase the 'average time' for the sensor (see menu system).

If the gauge is going to be fitted to a vehicle with high revving engines (>9000) the gauge MUST be rubber mounted (see diagram below).

[panel installation.bmp]

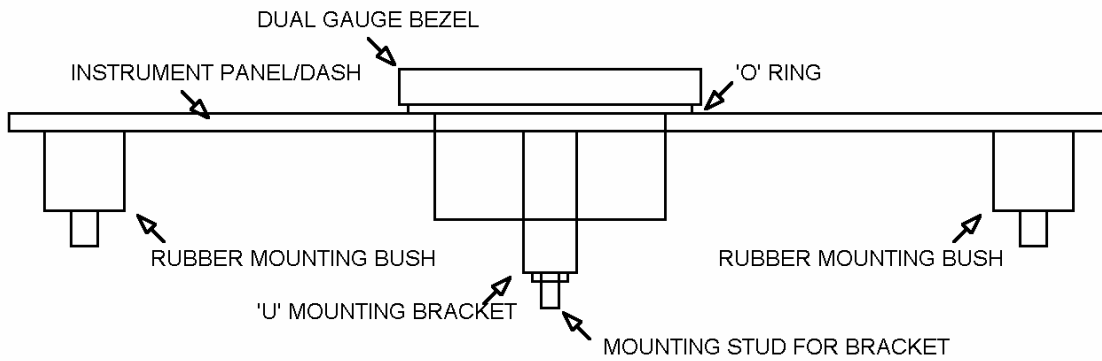

OR

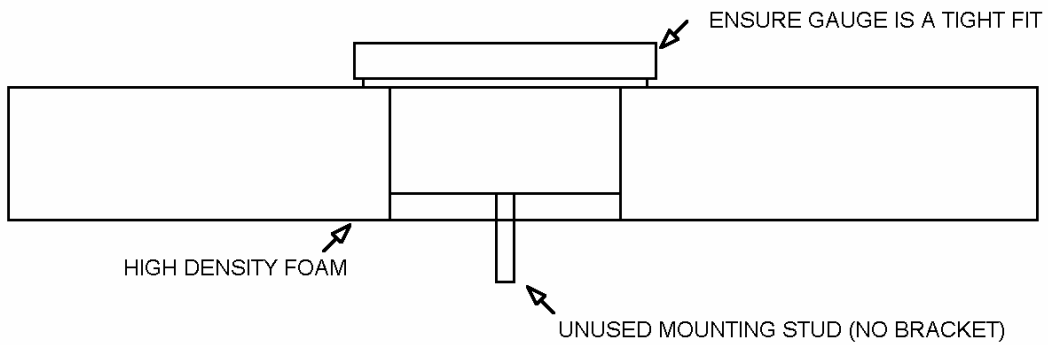

[sensor installation.bmp]

PRESSURE SENSOR MOUNTING

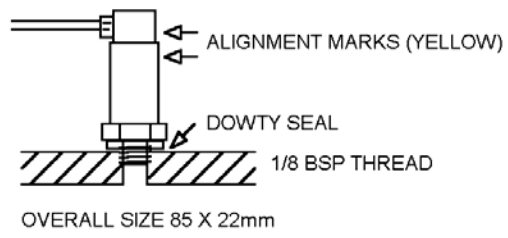

TEMPERATURE SENSOR MOUNTING

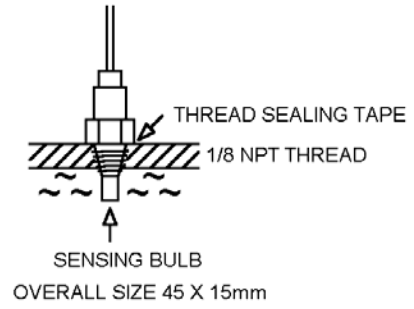

[US pressure sensor installation]

US VERSION PRESSURE SENSOR MOUNTING

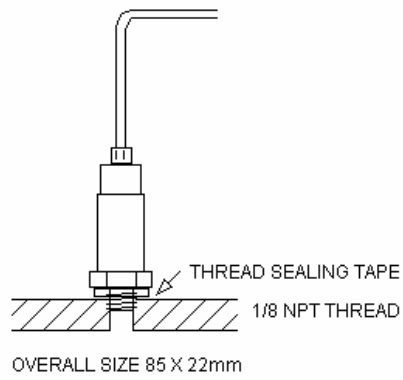

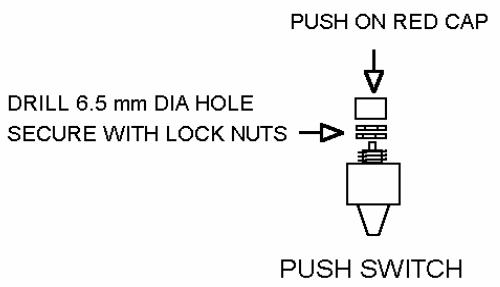
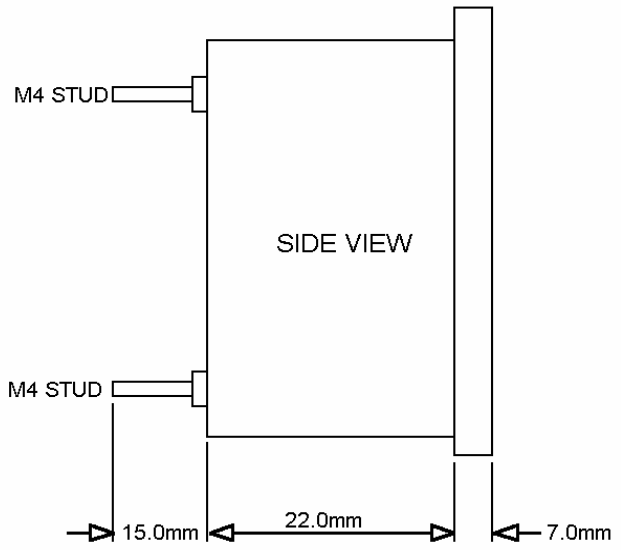
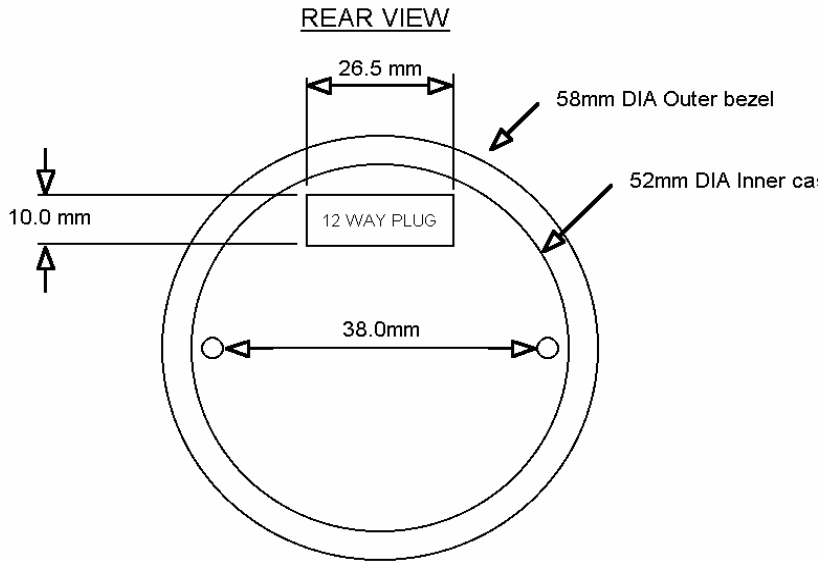

OVERALL SIZE 32 X 13 X 7mm

[Dg5 mechanical detail.bmp]

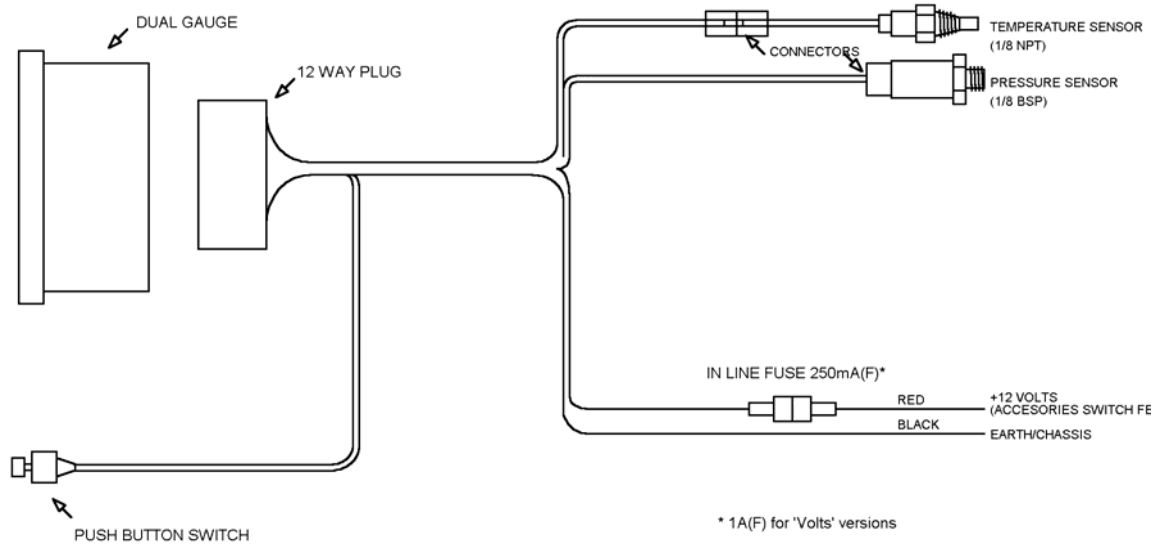

[Dg5 general schematic.bmp]

PLEASE NOTE: The black earth wire **MUST** be connected as directly to chassis as possible. It is highly recommended that it not be connected to an earth in the vehicle's loom as this often has a long indirect route to chassis (earth).

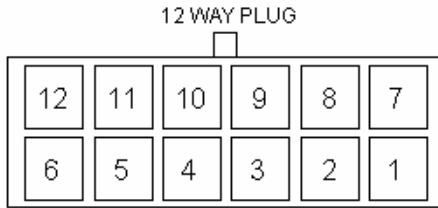

- NOTE 1) 28V MAXIMUM SUPPLY
- NOTE 2) NORMALLY OPEN SWITCH
- NOTE 3) 5V SIGNAL WITH 10K PULL DOWN
- NOTE 4) 250mA MAX LOAD
- NOTE 5) 100mA MAX LOAD

PIN NUMBER	FUNCTION	NOTE
12	GROUND (0V)	
6	+12 VOLTS BATTERY	1,4
8	CHANNEL 1 SENSOR +	
9	CHANNEL 1 SENSOR SIGNAL	3
10	CHANNEL 1 SENSOR -	
5	SWITCH (GROUND)	2
11	SWITCH (SIGNAL)	2
2	CHANNEL 2 SENSOR +	
3	CHANNEL 2 SENSOR SIGNAL	3
4	CHANNEL 2 SENSOR -	
1	EXTERNAL CHANNEL 1 ALARM -	5
7	EXTERNAL CHANNEL 2 ALARM -	5

PRESS SENSOR PLUG US VERSION

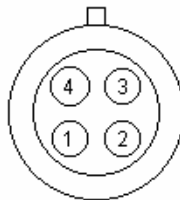
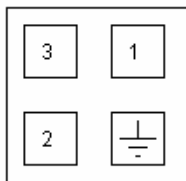

UK PIN No.	US PIN No.	FUNCTION	COLOUR
1	4	GROUND (0V)	GREEN
3	3	SIGNAL OUT	BLACK
2	1	+12V BATTERY	RED
⊥	NA	SENSOR CASE	NU

(REAR VIEW)

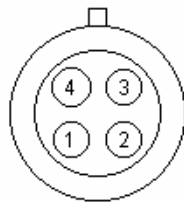

TEMP SENSOR PLUG
(REAR VIEW)

PIN NUMBER	FUNCTION	COLOUR
4	GROUND (0V)	GREEN
3	SIGNAL OUT	BLACK
2	+5V SUPPLY	RED
1		NU

[dg5 connector detail.bmp]

THERMOCOUPLE ADAPTOR BOX

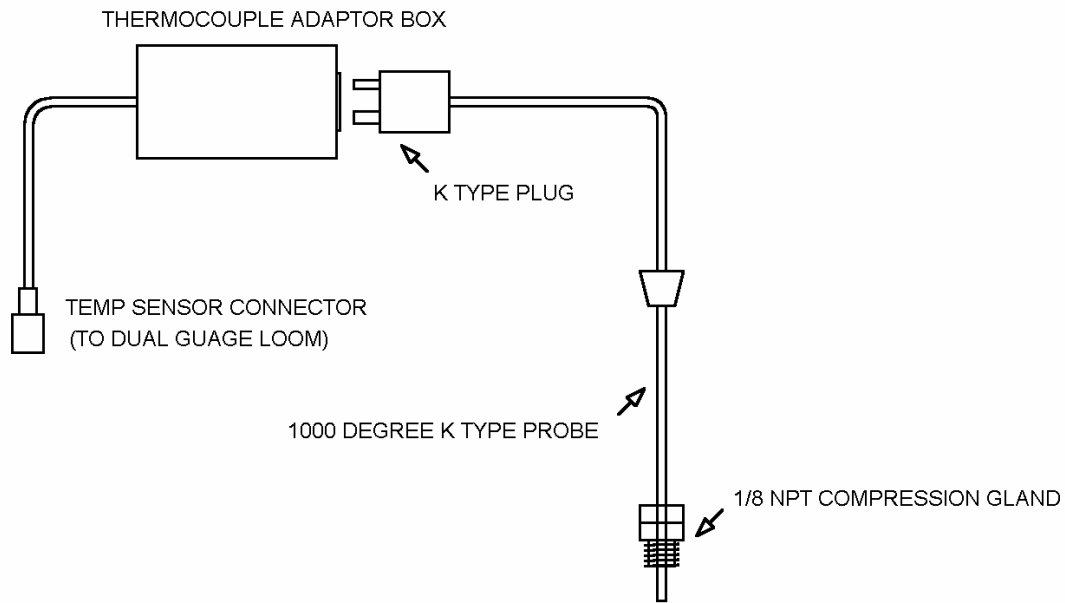

NOTES:

THE THERMOCOUPLE MAY BE GENTLY CURVED BY BENDING
DO NOT PUT SHARP BENDS IN IT.

SLACKEN OFF NUTS TO ADJUST LENGTH OF PROTRUDING THERMOCOUPLE

[thermocouple adaptor installation]

TURBO BOOST SENSOR INSTALLATION

The turbo boost gauge can be installed in a number of different ways, depending on what you wish to measure. Here are two typical ways to install the sensors to measure boost pressure.

INLET MANIFOLD

This is probably the ideal position as the vacuum can be read clearly with the sensors in this position. Here is how to do it:-

- 1) Without removing any engine components (air boxes etc), determine the best position of the pressure sensor so that it can be installed without interfering with any engine components (bear in mind the length of the sensor and connector). Try to choose a relatively flat part of the inlet manifold.
- 2) Remove the inlet manifold. This is recommended as it removes the possibility of swarf entering the engine.
- 3) Drill and tap the inlet manifold with a 1/8 BSP thread. For the dowty washer to seal properly, you will need a flat surface for it to seal onto. If necessary, lightly file and emery a smooth flat onto the manifold.

- 4) After ensuring there is no swarf remaining in the inlet manifold, screw the sensor into the manifold using the dowty seal and refit the inlet manifold to the engine.

TURBO HOSES

When fitted to the turbo hoses, the pressure sensor must be fitted to the *intercooler*. To do this you will need a short length of suitable aluminium tubing to construct a mounting for the pressure sensor.

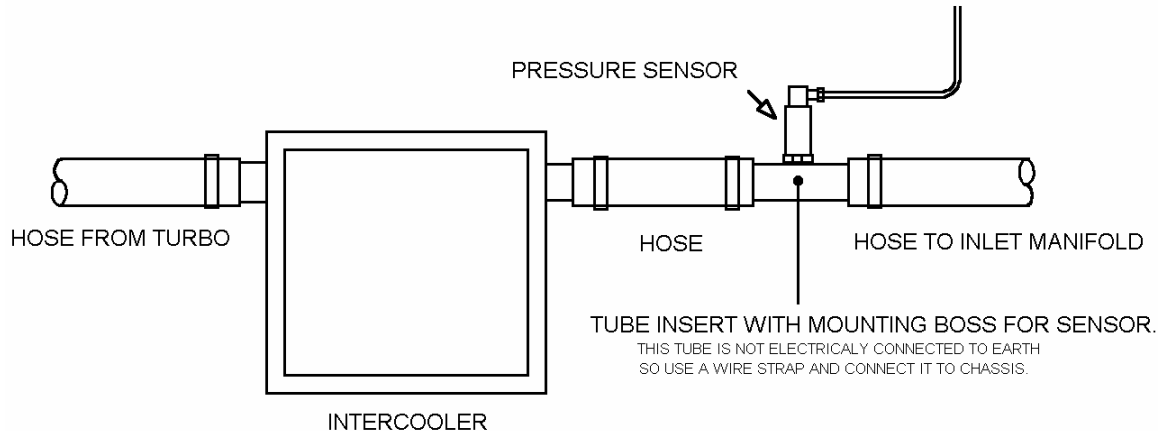

[turbo boost sensor installation]

Here is how to do it:-

- 1) A small boss will have to be welded to onto the aluminium tubing. Drill and tap the boss with a 1/8 BSP thread (see 3 inlet manifold method).
- 2) Screw the sensor into the tubes threaded boss using the dowty washer to seal it.
- 3) Ensure that there is no swarf left in the aluminium tubing or boss. Fit the tube into the hose that is coming from the intercooler and going to the inlet manifold.
- 4) Ensure hoses are tight with no air leaks.

Note: Please make sure that the aluminium tubing is connected to chassis to avoid electrical noise and static build up on the sensor body.

CABLE INSTALLATION, DO'S & DON'TS :-

DO'S

DO ensure that the black screened cables do not run next to power cables, especially if they are ignition power cables. Ideally, run all screened cables next to the chassis (earth).

DO ensure that any exposed plugs that are likely to get water spray are protected with rubber boots.

DONT'S

DO NOT allow cables to run through sharp edged apertures without protection.

DO NOT fix the cables next to or onto any surface likely to exceed 80 degrees Centigrade.

INSTRUMENT INSTALLATION DO'S AND DONT'S :-

DO'S

DO ensure that the sensors are screwed into metal that is connected to earth (chassis). If it is not, connect the metal to chassis with a short length of wire.

DO ensure that the instrument is slightly below the drivers head for the clearest view.

DO ensure that the back of the instrument is protected from any water spray that may occur.

DONT'S

DO NOT use a strong Nut-lock adhesive on the screw threads, use only a very light one, or silicone sealant.

OPERATING INSTRUCTIONS

Please ignore features and menu options that do not apply, according to model:-

When the gauge is switched on, it displays the model number (EG dg5) and the type of gauge (EG Pre, tem). This will vary according to model.

The gauge measure and displays the sensors according to factory default setting, but these can be easily customized to your own needs (see menu system section).

All the gauges settings are stored in the gauges memory, these are not lost once the power has been switched off.

The DG5 series of gauge has greatly increased resolution. It can now display 1 degree on a 1000 degree thermocouple, and it has a high resolution mode for x10 resolution at low readings (below 200). EG Pressure (PSI) can show 0.1 PSI resolution in high resolution mode to 199.9 PSI, and 1 PSI resolution from 200 to 232 PSI.

Also the backlight now has selectable colour, with adjustable brightness, and the display now operates over a wide temperature range to suit extreme cold and hot climates.

The button function can now be programmed to access the menu, and/or reset peaks, in addition to recall of maximums.

Because of the many variations in models, please note that the two displays on the gauge are referred to as channel 1 for the top of the display, and channel 2 for the bottom of the display (See below). Also where menu items are duplicated (as in a dual temperature version), the numbers on their menu refer to their channel. EG over temp set point menu items **ot1** and **ot2** refer to **ot** for channel 1 (top display item), and **ot2** for channel 2 (bottom display item).

Please note that there may be some additional or slightly changed menu functions as SPA are enhancing the range continuously. However they all work in a very similar way.

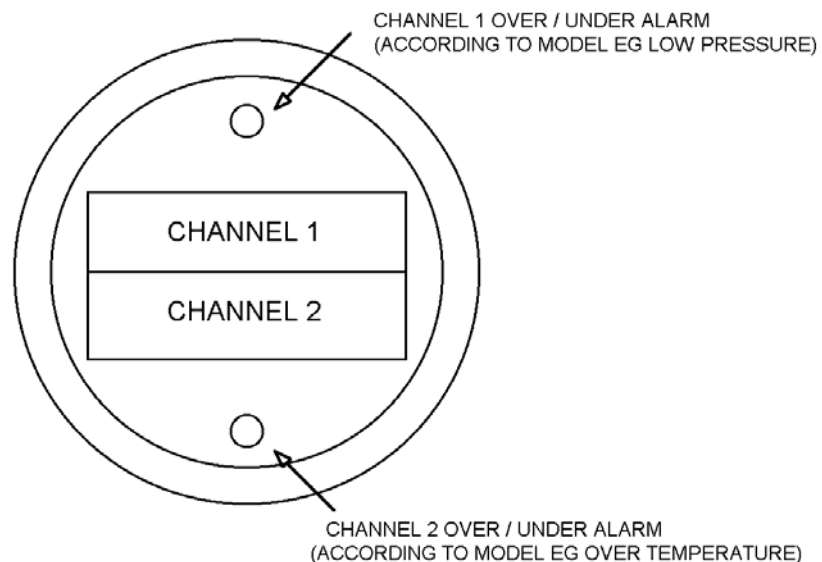

[Dg50 face.bmp]

MENU SYSTEM:-

To access the Dual Gauge system menu, you can either hold down the red button while you switch on the power, or if the menu is configured for button access (factory default), press and hold down the red button for more than 5 seconds. On the display you will see **tSt** on the LCD display. Now release the button. If you now press the button momentarily again you will see the display change to the next menu option. Keep pressing the button to familiarize yourself with the menu items. A brief sequential view of options and their meaning is shown below:-

Display shows:	What it does:
tSt	Used by SPA during production (ignore).
bL	Use this to set the backlight off, on with a red colour, or on with a green colour.
bri	Use this to set the backlight brightness.
rtP	Use this to reset the stored maximums (peaks).
oFF	Use this read the sensor and zero it (pressure only).
dEg	Use this to set temperature display units.
Uni	Use this to set pressure display units.
LP	Use this to set the gauges low-pressure alarm setting.
LP1	Use this to set the gauges low-pressure channel 1 alarm setting (dual press version).
tb	Use this to set the turbo boost gauges turbo boost setting. (Turbo boost gauge version)
ot1	Use this to set the gauges over temperature channel 1 alarm setting (dual temp version).
ELP	Use this to set the external low-pressure alarm setting.
ELP1	Use this to set the gauges external low-pressure channel 1 alarm setting (dual press version).
Etb	Use this to set the turbo boost gauges external turbo boost setting. (Turbo boost gauge version)
Et1	Use this to set the external over temperature alarm setting channel 1 alarm setting (dual temp version).
ot	Use this to set the gauges over temperature alarm setting.
ot2	Use this to set the gauges over temperature channel 2 alarm setting (dual temp version).
LP2	Use this to set the gauges low-pressure channel 2 alarm setting (dual press version).

Eot	Use this to set the external over temperature alarm setting .
Et2	Use this to set the external over temperature alarm setting channel 2 alarm setting (dual temp version).
ELP2	Use this to set the gauges external low-pressure channel 2 alarm setting (dual press version).
Lb	Use this to set the low battery warning setting.
At	Use this to set the averaging time for the channel 1 sensors (top of display).
tyP	Use this to set type of temperature sensor, or thermocouple.
EFL	Use this to set external alarms to flashing.
hr1	Use this to set the resolution of channel 1 (pressure).
hr2	Use this to set the resolution of channel 2 (temperature).
SFU	Use this to set the switch function of the red button.
Eng	Use this to access special menu function (see appendix).
rEt	Use this to exit the menu and return to normal gauge operation. Do not switch the gauge off after changing a menu setting. Always click onto the next menu item before switching off.

Press again and the menu will go back to **tSt**.

A detailed breakdown of the Dual Gauge menu options is shown on the following pages:-

tSt This is used by SPA during production. If you really want to see what it does, Press and hold down the red button. After 2 seconds the LCD lights up all segments and the LED's come on. To return to the menu, click the button.

bL Press and hold down the red button. After 2 seconds, the current backlight setting will be displayed. These are **oFF** (no backlight), **grn** (green backlight) and **rEd** (red backlight). Single click to change the current selection. To return to the menu, leave the button for 4 seconds.

bri Press and hold down the red button. After 2 seconds, the current brightness number will be displayed. Single click to increment (lighten) the LCD backlight, or press and hold again for 2 seconds and the brightness number will count up quickly. When the number reaches 15 it will go back to 0 (dark). To return to the menu, leave the button for 4 seconds.

rtP Press and hold down the red button. After 2 seconds the display will show ---. All maximum data is now reset.

oFF Use this to zero pressure sensors and custom sensors (see appendix), and view the voltage output of any sensor. It will read the offset value, and store it so as to 'zero' the pressure sensor at normal atmospheric pressure. To select which channel to read and zero, press and hold down the red button. After 2 seconds the display will show (channel) 1 corresponding to the sensor which displays the on the top display on the LCD. Single click to select the channel number you wish. Now release the button and after 4 seconds the display will the output voltage of the sensor selected (by the channel number). This represents the sensor output voltage at minimum in Volts. EG 1.00 V for a standard SPA 16 Bar pressure sensor. (1-5 volts output)

To 'zero' the sensor, press and hold down the red button. After 2 seconds, the display will change to --- and the offset displayed will be stored. Wait for the display to return to **oFF**.

Note: Although you can use this function to view the output voltage of any sensor, you are only allowed to 'zero' pressure channels. Non-pressure channels will display **NA** (not applicable) if you try to zero them.

dEg Press and hold down the red button. After 2 seconds, the display will show the current selection for temperature degrees. These are in **Centigrade**, and **Farenheight**. Single click to change the current selection. After changing the degrees, you will need to redo your temperature alarm set points as they will be reset to standard (105 Degrees C equivalent in whatever degrees are selected). To return to the menu, leave the button for 4 seconds.

Uni Press and hold down the red button. After 2 seconds, the display will show the current pressure units selection. These are in sequence **PSI**, **BAr** and **CM2** (KG/CM2). Single click to change the current selection. After changing the units, you will need to redo your pressure alarm set points as they will be reset to standard (25 PSI equivalent in whatever units are selected). To return to the menu, leave the button for 4 seconds.

LP /LP1 /LP2 Press and hold down the red button. After 2 seconds, the current low pressure alarm set point will be displayed. Single click to increment up, or press and hold again for 2 seconds and the set point will count up quickly. When the set point number reaches the full scale it will go back to 0 (zero alarm setting switches it off). To return to the menu, leave the button for 4 seconds.

tb Press and hold down the red button. After 2 seconds, the current turbo boost set point will be displayed. Single click to increment up, or press and hold again for 2 seconds and the set point will count up quickly. When the set point number reaches the full scale it will go back to 0 (zero alarm setting switches it off). To return to the menu, leave the button for 4 seconds.

ELP /ELP1/ ELP2 Press and hold down the red button. After 2 seconds, the current low pressure external alarm set point will be displayed. Single click to increment up, or press and hold again for 2 seconds and the set point will count up quickly. When the set point number reaches the full scale it will go back to 0 (zero alarm setting switches it off). To return to the menu, leave the button for 4 seconds.

Etb Press and hold down the red button. After 2 seconds, the current turbo boost set point will be displayed. Single click to increment up, or press and hold again for 2 seconds and the set point will count up quickly. When the set point number reaches the full scale it will go back to 0 (zero alarm setting switches it off). To return to the menu, leave the button for 4 seconds.

ot / ot1/ ot2 Press and hold down the red button. After 2 seconds, the current high temperature alarm set point will be displayed. Single click to increment up, or press and hold again for 2 seconds and the set point will count up quickly. When the set point number reaches the full scale it will go back to 0 (zero alarm setting switches it off). To return to the menu, leave the button for 4 seconds.

Eot /Et1 /Et2 Press and hold down the red button. After 2 seconds, the current high temperature external alarm set point will be displayed. Single click to increment up, or press and hold again for 2 seconds and the set point will count up quickly. When the set point number reaches the full scale it will go back to 0 (zero alarm setting switches it off). To return to the sub menu, leave the button for 4 seconds.

Lb Press and hold down the red button. After 2 seconds, the current low battery warning set point will be displayed. Single click to increment up, or press and hold again for 2 seconds and the set point will count up quickly. When the set point number reaches the 15.0 it will go back to 10.0. To return to the menu, leave the button for 4 seconds.

At Press and hold down the red button. After 2 seconds, the current pressure averaging time will be displayed. Single click to increment up, or press and hold again for 2 seconds and the set point will count up quickly. When the set point number reaches 25.0 it will go back to 0.1 (0.1 switches averaging off). To return to the menu, leave the button for 4 seconds.

tyP Press and hold down the red button. After 2 seconds, the display will show the current selection for temperature sensor type. These are in sequence **tEM** (standard brass temperature sensor), **tHi** (1000 degree thermocouple option) and **tLo** (255 degree thermocouple option). Single click to change the current selection. To return to the menu, leave the button for 4 seconds.

EFL (External flash on/off):- Press and hold down the red button, after 2 seconds display changes to the desired option. Use this to switch off external flashing if you wish to have the external warnings (or other devices) activate but without flashing.

Hr1 (High Resolution channel 1 on/off):- Press and hold down the red button, after 2 seconds display changes to the desired option. Use this to switch off the high resolution (x10 zoom) feature for channel 1. With this switched on, the display will show 10 times more resolution and auto scales for higher readings. EG in Low resolution mode pressure is displayed as 00 to 1999 PSI. In high resolution mode pressure is displayed as 0.0 to 199.9 PSI, and above this pressure range as 200 to 1999 PSI.

Hr2 (High Resolution channel 2 on/off):- Press and hold down the red button, after 2 seconds display changes to the desired option. Use this to switch off the high resolution (x10 Zoom) feature for channel 2. With this switched on, the display will show 10 times more resolution and auto scales for higher readings. EG in Low resolution mode temperature is displayed as 00 to 1999 degrees. In high resolution mode temperature is displayed as 0.0 to 199.9 degrees, and above this temperature range as 200 to 1999 degrees.

SFU Press and hold down the red button. After 2 seconds, the display will show the current selection for the switch function (what happens when you hold down the red button in normal gauge operation). These are in sequence **rMU** (recall maximums and after 5 seconds access the menu), **rCL** (recall maximums only) and **rrS** (recall maximums and after 5 seconds reset maximums). Single click to change the current selection. To return to the menu, leave the button for 4 seconds.

Eng For engineering access (code protected)

rEt Press and hold down the red button. After 2 seconds, the display will show --- . Release the button and

the gauge will restart normally.

FLASHING SYMBOLS:-

oil can = Low Pressure. The pressure is at or below the programmed set point. This is not displayed on the turbo boost model.

hot temp = Over Temperature. The temperature is at or above the programmed set point.

battery = Low Battery volts. The Instrument supply voltage is below the low battery set point. If the supply goes below 7.5 volts the instrument resets itself.

WARNING MESSAGES :-

FL = **FauLt**. The sensor output voltage is zero, it has become unplugged, damaged, or wiring to the sensor is disconnected or faulty. (Not applicable to thermocouple modes).

Warning alarms are accompanied by an internal flashing LED except the turbo boost which lights the red LED continuously showing over boost.

The warning lights are also available externally via the socket.(see wiring diagram) External LEDs or relays can be connected, and these can be programmed to activate independently of the internal LEDs, and programmed for flash or direct drive.

SPECIFICATIONS:-

INPUT VOLTAGE 10-16 VOLTS (28v ABSLOUTE MAX, PULSE ONLY)
CONSUMPTION 16 mA @ 12 VOLTS (48 mA BACKLIT)

ACCURACY:-

PRESSURE Better than 2% @ 232 PSI (1 PSI = 0.069 BAR)
TEMPERATURE Better than +/- 2 °C from -55 to +150 °C
VOLTAGE +/- 0.1v over 9-16 volts.

CALIBRATION:- DIGITAL

DATA STORAGE:- EEPROM

WEIGHT:- 325g INCLUDING SENSORS,CABLES,ETC

SIZE:- 52mm DIA x 30mm (BEZEL 58mm DIA)

SENSORS FIXING THREADS:-

TEMPERATURE: 1/8 NPT or M16x1.5 all 12.7mm long

PRESSURE: 1/8 BSP x 12.7mm (WILL FIT 1/8 NPT)

CABLE LENGTHS:- PRESSURE & TEMPERATURE - 108"

POWER SUPPLY - 12"

SWITCH LEAD - 24"

ABSOLUTE MAXIMUM RATINGS:-

INPUT VOLTAGE: 28 VOLTS (pulse only)

MAX PRESSURE: 232 PSI (for 16 BAR sensor)

2900 PSI (for 200 BAR sensor)

PROOF PRESSURE = 2 times max pressure

TEMPERATURE - 150 °C (brass sensor), 255/1000 °C (thermocouples)

INSTRUMENT TEMPERATURE -20 to +70 °C

Appendix

A) External alarm outputs

The external alarm outputs can drive loads up to 100mA. **DO NOT** use ordinary bulbs as these take much more than 100mA and will damage the gauge.

To fit an external LED, please use a **12v type**. These have a built in current limiting resistor and will only draw around 25mA. See diagram below:-



[external led.bmp]

You can order 10mm panel mount leds, complete with wire tails and pins from SPA Design or via your local SPA distributor.

To drive control relays, you need to select a relays of more than 120 Ohms coil resistance (so it draws less than 100mA). You will also **MUST** use a protection diode to clamp the high voltage back EMF resulting from the relay coil when it is de-energised. Please follow the diagram below:-

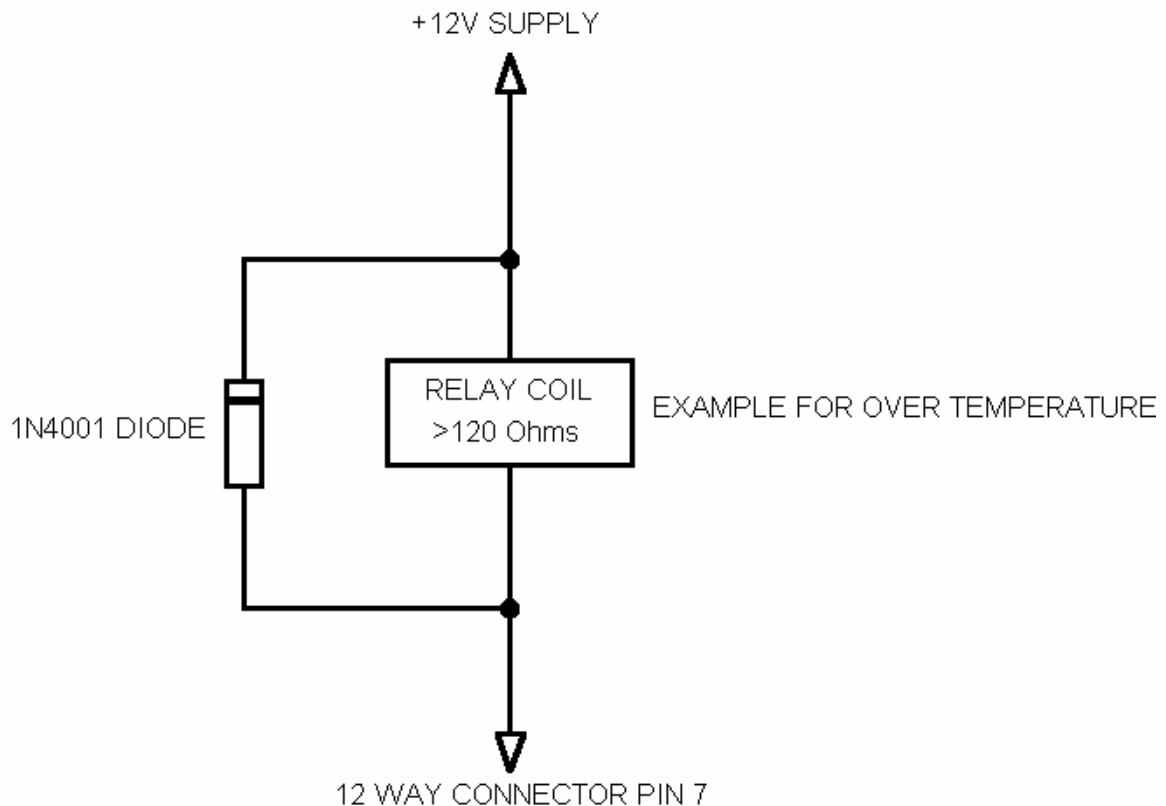

[external relay.bmp]

To avoid the relay pulsing on and off with the flashing alarm, you must set the **EFL** (external flash) to **oFF** (see menu section).

B) Special Menu section

To access the special menu area you need to enter a code in the **Eng** menu item. Goto the **Eng** menu item. Press and hold down the button for 2 seconds and the display shows to 000. Press and hold to scroll the number to 113. Wait for 4 seconds, and then the special menus will appear:-

dbA Dead band control:- If the pressure value to be displayed is less than the dead band value (whether positive or negative) the display is set to zero. This is to avoid displaying low level drift and flicker which some customers find annoying. The factory default for this is 1, but can be increased to a maximum of 10 of desired.

ChA This is a sub menu system for changing the scaling and unit parameters for custom sensor set-ups. You cannot change the type of sensor as this is determined by the construction and labelling of the gauge itself, but you could replace the SPA pressure sensor with another pressure sensor for example.

To access these parameters, first you select the analog channel that you wish to setup, and then you are

taken through a series of sub menus for that channel. The setup is identical for both channels. Press and hold down the red button. After 2 seconds, the display will show (channel) 1. Single click to increment the channel number to the desired channel. When you have selected the channel, leave the button for 4 seconds and the display will change to **FSC**. This is the first of 4 sub menus.

All sub menus work in the same way. To access each one press and hold down the left button, after two seconds the current setting will be displayed. Now single click to select, or press and hold to count up. If you do not wish to access the sub menu, just single click and the next one will be displayed.

Here is a list of all sub menus and there function: -

- FSC** Use this to change the default full-scale sensor setting.
- dEC** Use this to change the default decimal point setting (none, 1 or 2 places).
- SPn** Use this to change the default span sensor setting.
- oFF** Use this to change the default offset sensor setting.

If you single click again, you will return to the **ChA** menu item.

Here is a break down of each sub menu item: -

FSC, Press and hold down the red button. After 2 seconds, the full-scale number will be displayed. This represents the value to display when the sensor output voltage is at maximum. EG 232 PSI for a standard SPA 16 Bar pressure sensor.

Single click to increment up, or press and hold again for 2 seconds and the alarm number will count up quickly. When the number reaches the full scale it will go back to 1. To return to the sub menu, leave the button for 4 seconds.

dEC, Press and hold down the red button. After 2 seconds, the current decimal point number will be displayed.

Single click to increment up. When the number reaches 2 it will go back to 0 (no decimal point). NOTE: If you set a decimal point of 2, and have High resolution switched on (IE 3 decimal places will be shown), then no negative readings are allowed. To return to the sub menu, leave the button for 4 seconds.

SPn Press and hold down the red button. After 2 seconds, the full-scale span number will be displayed.

This represents the sensor output voltage swing at maximum in Volts. EG 4.00 V at 232 PSI for a standard SPA 16 Bar pressure sensor. (1-5 volts output)

Single click to increment up, or press and hold again for 2 seconds and the span number will count up quickly. When the number reaches 5.00 it will go back to 1. To return to the sub menu, leave the button for 4 seconds.

oFF, Press and hold down the red button. After 2 seconds, the offset number will be displayed. This represents the sensor output voltage at minimum in Volts. EG 1.00 V for a standard SPA 16 Bar pressure sensor. (1-5 volts output)

Single click to increment up, or press and hold again for 2 seconds and the span number will count up quickly. When the number reaches 5.00 it will go back to 1. To return to the sub menu, leave the button for 4 seconds.

If you single click again, you will return to the **ChA** menu item.

NOTE: You must not change the units or degrees (**Uni**, **dEg** or **tyP** menu's) after setting up the above channel parameters. If you do, this will restore standard channel parameters for SPA sensors. Of course if you wish to restore standard parameters, then simply use these menus as appropriate.

Brake Bias Kit Addendum

PRESSURE SENSOR INSTALLATION:-

Install one of the 4 way adapters in the front brake line, and the other one in the rear brake line. Screw in the pressure sensors to the bottom port of the 4 way adapters using the supplied Dowty seals. Then use the bleed nipples (on the top port of the adapters) to bleed the air out of the adapters. If you screw the bleed nipples out temporarily, you can fill up the 4 way adapters with brake fluid to purge out most of the air. Then bleed the rest of the brake system in the normal way.

If you spill brake fluid onto the sensor cable or connectors, make sure that you wipe it off thoroughly.

Push on the sensor plugs as shown on the schematic.

THE PLUG WILL ONLY GO ON ONE WAY, REFER TO SCHEMATIC DIAGRAM.

Then tighten the central screw on the plugs. Do not over tighten, they have a rubber gasket that will seal to IP65 specification. Please use the menu option **oFF** (see dual gauge manual) to zero each sensor after installation.

PRESSURE SENSOR INSTALLATION

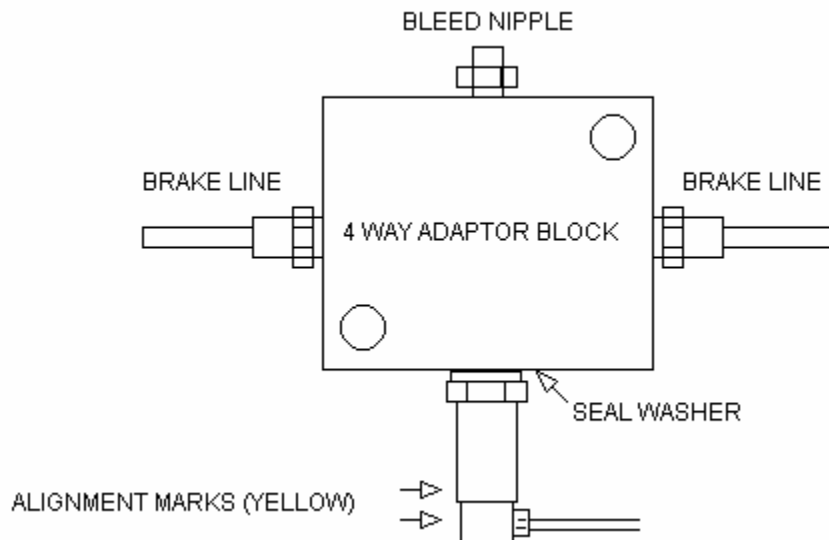

There are two extra menu items for the brake bias kit not in the standard dual gauge manual:-

rCP (Recall peaks) Press and hold down the red button. After 2 seconds the display will show the maximum pressures stored since the last reset operation (see **rtP** in manual)

PE (Peak ratio) Press and hold down the red button. After 2 seconds the display will show **rAt** ratio for the maximum pressures stored above.

Also the standard **SFU** menu item has been replaced with **vIE** and a special **SFU** and works as follows:-

vIE (View):- This is used to select what is viewed on the brake bias LCD, and what the view changes to when the red button is pressed. If **PrE** is selected, then the LCD normally shows pressure, and then shows percent bias when the red button is pressed. If **bIA** is selected, then the LCD normally shows percent bias, and then shows pressure when the red button is pressed. To change the view selection, press and hold down the red button, after 2 seconds display changes to the desired option.

SFU Press and hold down the red button. After 2 seconds, the display will show the current selection for the switch function (what happens when you hold down the red button in normal gauge operation). These are in sequence **vIE** (view pressure/bias only), and **vME** (view pressure/bias and after 5 seconds access the menu). Single click to change the current selection. To return to the menu, leave the button for 4 seconds.